

DETC2007-35604

EXPLORING THE USE OF FUNCTIONAL MODELS AS A FOUNDATION FOR BIOMIMETIC CONCEPTUAL DESIGN

**Andrea Tinsley, Prem A. Midha, Robert L. Nagel,
Daniel A. McAdams, and Robert B. Stone**
University of Missouri-Rolla
1870 Miner Circle
Rolla, MO 65409

L.H. Shu
University of Toronto
5 King's College Road
Toronto, Ontario M5S 3G8 Canada

ABSTRACT

The natural world provides numerous cases for analogy and inspiration. From simple cases such as hook and latch attachments to articulated-wing flying vehicles, nature provides many sources for ideas. Though biological systems provide a wealth of elegant and ingenious approaches to problem solving, there are challenges that prevent designers from leveraging the full insight of the biological world into the designed world. This paper describes how those challenges can be overcome through functional analogy.

Through the creation of a function-based repository, designers can find biomimetic solutions by searching the function for which a solution is needed. A biomimetic function-based repository enables learning, practicing and researching designers to fully leverage the elegance and insight of the natural world. In this paper, we present the initial efforts of functional modeling natural systems and then transferring the principles of the natural system to an engineered system.

Four case studies are presented in this paper. These case studies include a biological solution to a problem found in nature and engineered solutions corresponding to the high level functionality of the biological solution, i.e., a fly's winged flight and a flapping wing aircraft. The case studies show that unique, creative engineered solutions can be generated through functional analogy with nature.

1 INTRODUCTION

The natural world contains some of the most elegant, innovative and robust solution principles and strategies. Biomimetic design aims to fully leverage the insight of the natural world into the engineered world. Because of numerous challenges, biomimetic design is still undeveloped as a method for formal concept generation. Allowing design engineers formal and full access to the solution principles and strategies of the natural world remains beyond current methods and knowledge.

At times, engineered technologies are unable to implement the physical principles used in the biological system. Articulated-wing flying vehicles are one example. Prior to the initial flight by the Wright brothers with fixed-wing flight, articulated-wing flight was attempted but failed. At the time, fixed-wing flight proved more

feasible. However, articulated-wing flight is now possible, allowing for micro and nano air vehicles that fly at Reynolds numbers infeasible with fixed-wing flight.

Another, and more fundamental challenge, is that the effort and time required to become a competent engineering designer creates significant obstacles to becoming sufficiently knowledgeable about biological systems to effectively execute biomimetic design (and of course, the converse could be said).

Functionally based concept generation methods provide a unique opportunity to extend biomimetic design and integrate it fully into engineering design practice. In the last three decades, concept generation has made significant advances from art to science, from the informal to the formal. Methods are continuously being developed, tested and implemented in industry and taught to our engineering community [1]. Inherent to this formalization of conceptual design is the recognition that devices are designed to solve specific functions. Thus, even if not explicitly performed, specifying and modeling the desired function of a product or system is fundamental in the conceptual design process.

Additionally, representing products by function has enabled the creation of design repositories that allow designers to access solution principles that are outside their personal knowledge or expertise [2-5]. The ability of functional representation to allow designers to access such design information is a key strength of extending biomimetic design through the method of functional modeling. If extending biomimetic design to the full range of designers, design researchers and design students requires extensive knowledge in biology, the insight of the natural world will never be fully accessible to engineering design.

The objectives of the research presented in this paper are to create the methods and discover the knowledge needed to enable a function-based biomimetic design repository. First, a brief summary of previous work in biomimetic design will be provided. Next, the research methodology that was followed to generate the case studies found in the fourth section of this paper will be discussed. Finally, conclusions reached thus far in this research will be discussed as well as a summary of future work that remains to be completed.

2 BACKGROUND AND RELATED WORK

Numerous biomimetic designs have been developed, where in most cases, the engineered system directly emulates the natural system. For example, prosthetic replacements are a biomimetic design mimicking bone structure. However, novel and non-obvious solutions may require the natural system be viewed from a different perspective than an attempt to directly copy nature. The main focus of this research is to provide engineers with a method of learning enough about biological phenomena to inspire novel designs. For example, while plants may be stationary, a closer inspection of the process of reproduction may give rise to ideas about transportation devices and distribution processes [6]. This approach to biomimetic design has been applied to design for remanufacture [7] and microassembly processes [8]. In large part, we are looking at nature as an analogy to inspire an innovative design.

Analogy with nature has been shown to inspire novel ideas. The Indian Institute of Science in Bangalore is developing a biological and engineering design knowledge database using verbs, adjectives, and nouns for categorization [9]. This is similar to the approach we are presenting here. A crucial difference is that IIS's approach is largely based on overall descriptions and cases of functionality, whereas the approach proposed here formally uses the Functional Basis [10] and a detailed functional model of the system for analogy.

Research at the University of Texas by Linsey et al. explores a method of breaking down products into a vocabulary that can then be easily transferred to an analogous system [11]. It does not cover biomimetics per se, but the same concepts can apply to biomimetic design. It is proposed that representing systems in a semantic form increases the probability of innovation of novel, analogous systems.

Other research by Singh et al. at the University of Texas explores transformation principles in biomimetic design [12]. A product that can transform to fulfill multiple functions can increase efficiency, reduce cost, and increase weight saving. In Singh's work, a methodology is developed for creating innovative products with broader functionality through the exploration of transformation design principles. The paper details case studies in nature, patents, and products. The three transformation principles deduced from the case studies are "Expand/Collapse," "Expose/Cover," and "Fuse/Divide." Accompanying these are transformation facilitators, which include "Common Core Structure," "Composite," "Conform with Structural Interfaces," "Flip," "Function Sharing," "Furcation," "Generic Connections," "Modularity," "Nesting," "Shared Power Transmission," and "Shelling."

The Biomimicry Institute [13, 14] is concerned with training biologists to better assist engineers in biomimetic design. This includes performing case studies and creating a database of biological solutions searchable by "challenges," "strategies," "organisms," "people," "citations," and "products."

The Berkeley Lower Extremity Exoskeleton is a wearable robotic exoskeleton for the legs that augments the strength and endurance of the human body through sensory systems and powered linear hydraulic actuators [15]. This system was designed for material transport over rugged terrain, where wheeled vehicles may be incapable of navigating. Clinical gait analysis was used to determine the kinematics and dynamics of walking. This form of bio-inspired design falls under the category of direct emulation, in which one tries to make an exact copy of the inspiring system.

Swimming microrobots developed from the observation and analysis of the motility mechanism of prokaryotic and eukaryotic microorganisms could potentially reach currently inaccessible areas of the body [16]. This would allow for minimally invasive surgery, localized drug delivery, and local screening for diseases. Mathematical modeling and analysis of flagellar motion in microorganisms led to the design of some mechanical counterparts. These robots were designed using more of a principle emulation level

of biomimetic design. The solution is not a direct copy of the biological phenomenon, but uses the same principles and strategies.

3 RESEARCH METHODOLOGY

Biomimetic design as a formal method for concept generation is far from a developed science. Additionally, as formally combining functional modeling and the Functional Basis with biomimetic design is new, the basic research approach used here is largely exploratory resulting in the discovery of new knowledge. In general, our approach is to identify existing biomimetic designs, create the functional model for both natural and engineered systems and explore the similarity, difference and analogy between the solutions at the sub-function level.

One of the key things explored is the modeling and drawing of analogies at different scales or levels of biological organization. Certain levels of biological organization, particularly organ (e.g., heart, leaf, etc.) to organism (e.g., animals and plants) present themselves naturally as potential sources for design inspiration and imitation due to the familiarity with biological phenomena at these levels. Prior research, however, has shown that useful biological phenomena can be found at multiple levels of biological organization [7, 8]. Principles found from the molecular to ecosystem scales of organization can lead to useful engineering solutions. Furthermore, analogous biological phenomena from less familiar levels of organization may lead to more novel solutions.

The research approach is the opposite of what the final design approach will be. Rather than start with a design need and the associated required function, we start with the natural system and extract an engineered system from it. Natural systems that solve problems in a unique way are identified, and either a known biomimetic design is identified, or one is synthesized by the research team. In the cases where there is an existing biomimetic design, the black box and functional models for the natural and engineered system are developed (they are largely the same). In the case where synthesis of an engineered system is needed, the research team explores both the black box model and functional model of the natural system in an effort to either identify a functionally analogous engineered system or create a new design. With both functional models of natural and engineered systems, morphological matrices are developed and the analogy between the two systems is analyzed.

4 CASE STUDIES

Four case studies are presented in the following section. Each study includes a brief description of a biological system, the system's functional model, the corresponding morphological matrix, an overview of engineered systems that share the same black box functionality as well as significant functionality throughout a biological system, and the engineered systems' functional models and morphological matrices. After all of these items have been presented, a short summary will describe the similarities, differences and analogies between the biological system and its corresponding engineered system.

4.1 Case Study 1 – Housefly

Since at least 500BC in ancient Greece, humans have been fascinated with birds and other flapping wing creatures. Fascination has spawned not only myths and fairy tales, but also the imagination of designers and engineers to *mimic biology*. During the 1400s, Leonardo da Vinci studied the flight of birds and became one of the first to sketch out a man-powered ornithopter, but it took until 1870 for the first successful ornithopter to be flown 70 meters by its builder Gustave Trouvé [17]. Today, biomimicry of flapping flight continues to fascinate engineers and designers who continue to try to fully capture the gracefulness and efficiency of the natural world. Figure 1 shows some modern examples of ornithopters.



a. Manned Ornithopter from University of Toronto Design Team



b. Sean Kinkade's Radio Controlled Skybird



c. Albert Kempf's Radio Controlled Truefly

Figure 1: Modern Examples of Ornithopters [17]

Micro air vehicles or MAVs used for military reconnaissance have spawned a keen interest in ornithopters. Micro air vehicles, being considerably smaller than previously designed ornithopters, have spawned interest in the biomimicry of common houseflies (Fig. 2). Houseflies have an incredible range of maneuverability. They are able to make 6 full turns per second and recover lift within a few microseconds from impacting a solid surface. Flies have numerous sensors allowing for their quick reflexes and instinctive motion [18].



Figure 2: Housefly [19]

A common housefly has been modeled functionally for a MAV project being researched at the University of Missouri-Rolla. The housefly functional model used for the MAV project, provided in Fig. 3 and 4 captures the fly's sensory abilities as well as its winged and *pedal* motion. For the case of the MAV project, the housefly functional model was generated by reverse engineering nature to gain an understanding during the conceptual design phase.

MAV researchers were interested in gaining an understanding of the sensory and mobility aspects that would be required to mimic nature's design with engineering solutions. The functional model imports biological energy, which is converted into a useable form, stored, supplied, and distributed throughout the fly. Sensory aspects modeled, using the *detect* function, include compound eyes, antennae, hairs, halteres (used in aerial balance and guidance), taste, smell, temperature, and humidity. A *process status* function-flow block models the housefly's processing of status signal information from each of the detect function blocks. The status signals are converted to controls and routed to the housefly's mobility. Mobility aspects modeled include both of the housefly's wings and six legs. A detailed discussion of insect flight including the complexities of fly aerodynamics can be found in the work of Michael Dickinson [20].

Due to complexities of sensor and mobility design, the UMR MAV and many other MAVs are not mature enough to compare with the complete housefly at a function-form (morphological) level. For this reason, the flight mobility was extracted from the housefly functional model and compared to a simpler MAV, which provides an engineering solution for only the flight aspect of the housefly.

The Sparrow Flapping Wing Micro Air Vehicle (FWMAV), shown in Fig. 5, developed at the University of Delaware mimics the flight aspect of a common housefly [21]. The simplicity of this model is the result of the exclusion of all sensors and navigational control. It consists solely of a power source, power train, wings and chassis, thus allowing it to fly freely in circular paths. The wings of the FWMAV are directly analogous to nature, with their optimization of weight, local and overall stiffness, and fluid dynamics properties.

The extracted housefly wing mobility functional model can be directly compared to a functional model of the Sparrow FWMAV. The extracted housefly wing functional model in Fig. 6 imports biological energy into the system. The biological energy is converted to a usable form and stored. Once needed by the housefly, it is supplied and distributed to each of the housefly's wings. The biological energy is converted to mechanical energy, which is transferred and changed through muscle cells. The energy is regulated to control the housefly's velocity and converted to pneumatic energy representing the housefly's flight. Surrounding air is imported into the system and acted upon by the pneumatic energy as a result of the wings overall motion.

The functional model of the Sparrow FWMAV, provided in Fig. 7 is largely the same as the common housefly wing functional model provided in Fig. 6. The FWMAV, like the housefly, imports energy to fuel the system; only the energy used by the FWMAV is electrical energy. The electrical energy is stored in the system and supplied as needed. Once supplied, the electrical energy, like the biological energy in the housefly must be converted to mechanical energy. Where the housefly uses muscles for this conversion, the FWMAV uses an electric motor. Through a type of gear train, the mechanical energy is changed and transferred to actuate the wings. The FWMAV's wings, just like those of the housefly, import air and convert mechanical energy to pneumatic energy resulting in the overall motion of the FWMAV. The combined morphological matrix of the Fly's and FWMAV's functional models is provided as Table 1.

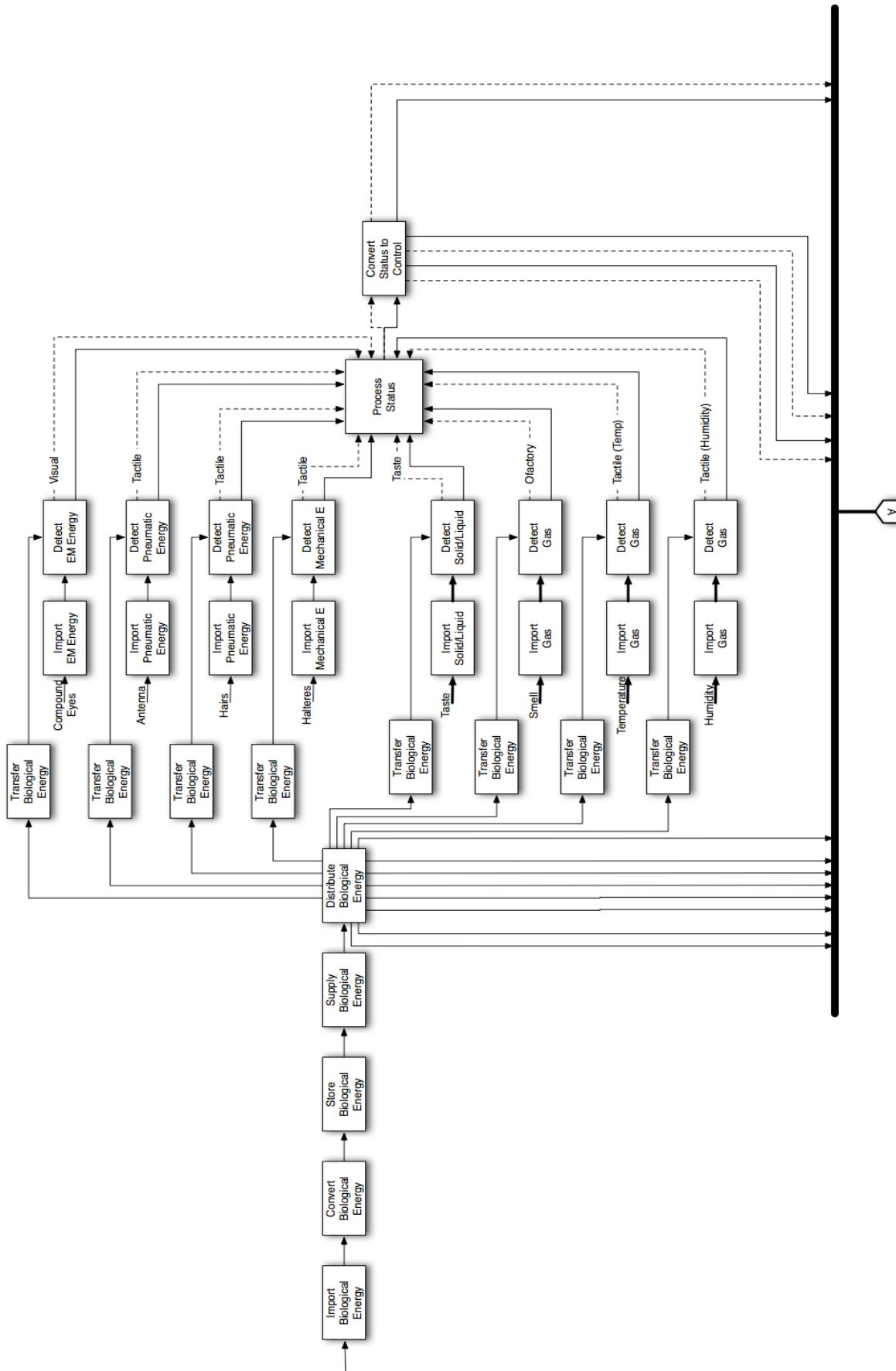

Figure 3: Housefly functional model

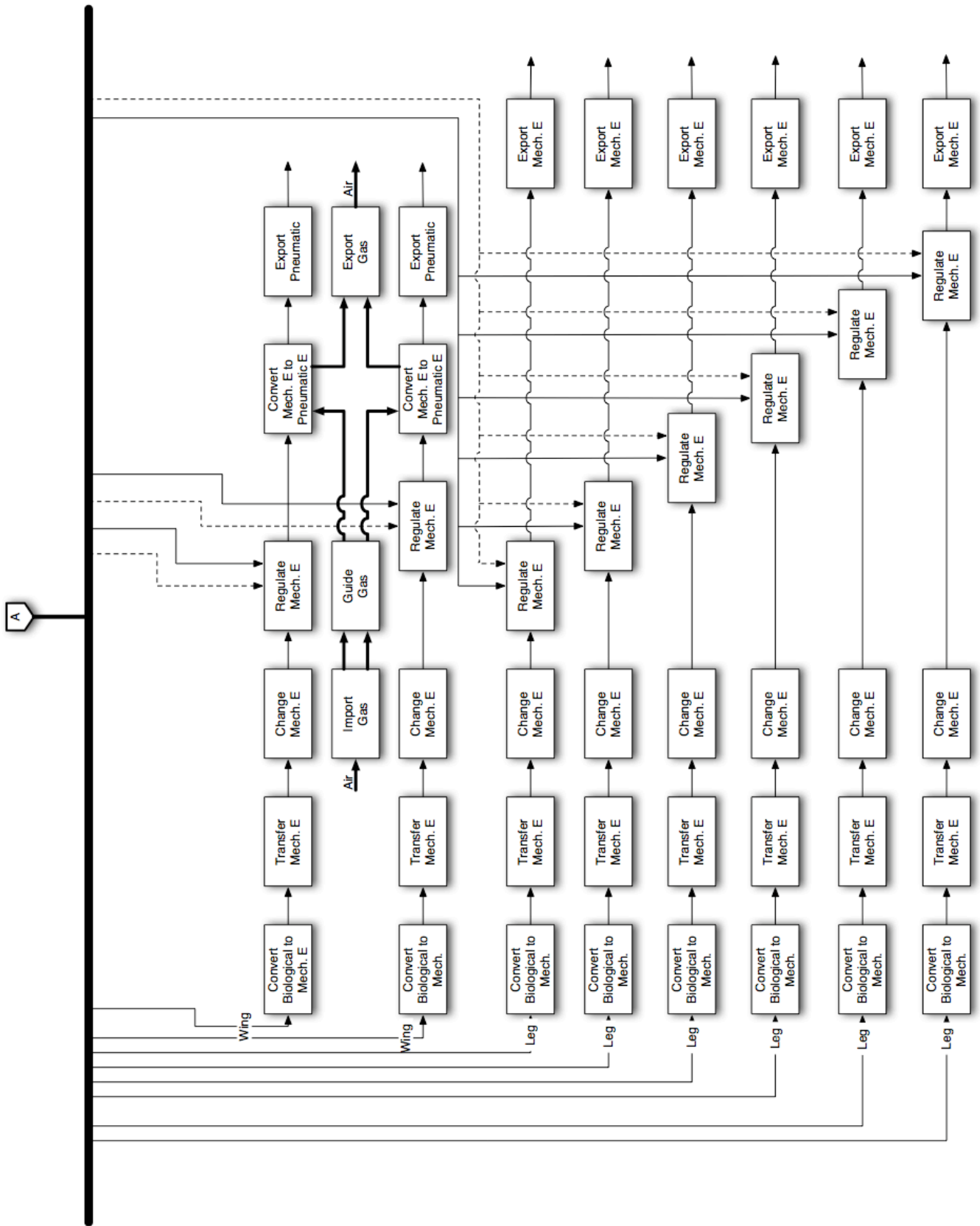

Figure 4: Housefly functional model



Figure 5: Sparrow Flapping Wing Micro Air Vehicle [21]

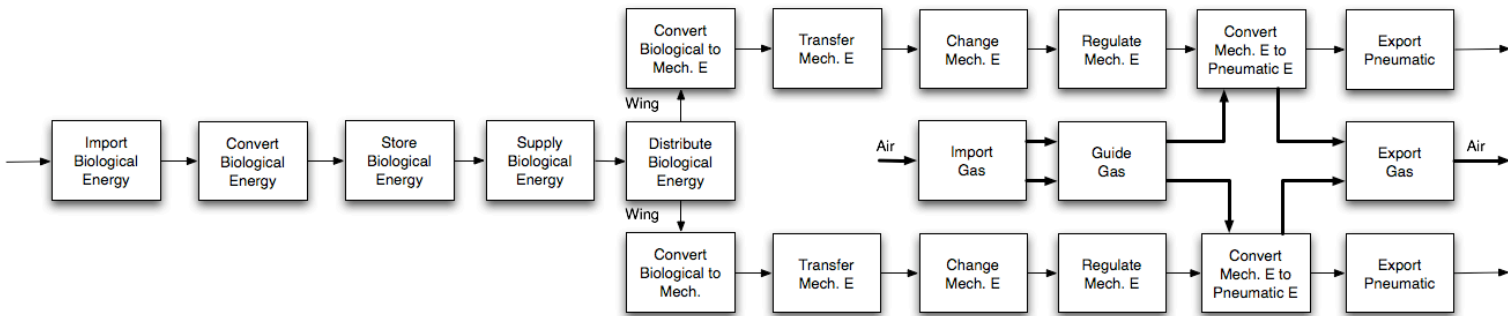

Figure 6: Flight Mobility from the Housefly Functional Model

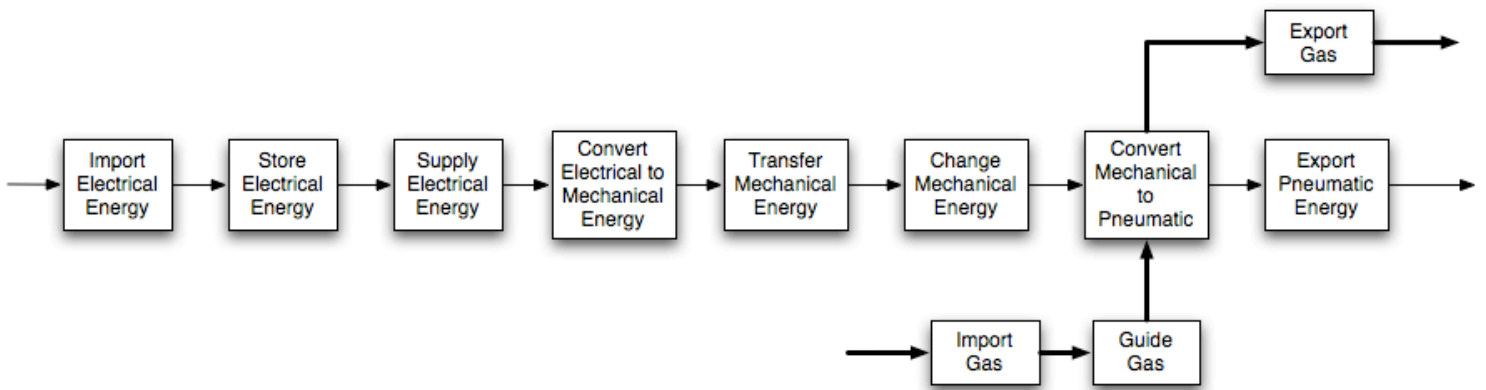

Figure 7: Functional Model of Sparrow Flapping-Wing Micro-Air Vehicle

Table 1: Combined morphological matrix for Housefly and Sparrow FWMAV

Function-Flow Pairs		Primary Functionality	Components	
Natural Solution	Engineered Solution		Natural Solution	Engineered Solution
Import Biological Energy	Import Electrical Energy	Import	Mouth	Battery
Convert Biological Energy	Convert Electrical Energy	Convert	Digestive Enzymes	Battery
Store Biological Energy	Store Electrical Energy	Store	Lipids	Battery
Distribute Biological Energy	Distribute Electrical Energy	Distribute	Blood	Battery
Supply Biological Energy	Supply Electrical Energy	Supply	Muscles	Battery
Convert Biological Energy to Mechanical Energy	Convert Electrical Energy to Mechanical Energy	Convert	Muscles	Motor
Transfer Mechanical Energy	Transfer Mechanical Energy	Transfer	Muscles	Gear train
Change Mechanical Energy	Change Mechanical Energy	Change	Muscles	Gear train
Regulate Mechanical Energy	Regulate Electrical Energy	Regulate	Brain	Battery
Convert Mechanical Energy to Pneumatic Energy	Convert Mechanical Energy to Pneumatic Energy	Convert	Wings	Wings
Export Pneumatic Energy	Export Pneumatic Energy	Export	Wings	Wings
Import Gas	Import Gas	Import	Air	Air
Guide Gas	Guide Gas	Guide	Wings	Wings
Export Gas	Export Gas	Export	Air	Air

4.2 Case Study 2 – Armadillo

The defense mechanism of certain species of armadillo has a unique functionality, which upon alarm, provides complete shielding from potential enemies and provides an opportunity for engineers and designers to employ biomimicry by learning from the armadillo’s shielding mechanism [12]. The *Tolypeutes* species of armadillo, which is found in South America, is the only species of armadillo that can roll itself into a ball when it feels threatened by a predator. This type of armadillo, also called the southern three-banded armadillo, has three bands along its back, which allow it to roll up into a ball only exposing its armor. The armor is made of plates of dermal bones that are covered in overlapping scales called “scutes.” This protective armor covers the animal’s tail, head, feet, and back. Smaller predators are not be able to break the armor of the armadillo when it is in its defensive position [22].

Engineering design can take cues from this unique defense mechanism through the study of the armadillo’s armor reconfiguration, and comparison to other embodied designs with similar high-level functionalities. For the armadillo, two engineered systems were studied with the same basic black box function as the southern three-banded armadillo. These systems include a retractable stadium roof and the Lexus SC430 convertible. All three systems (armadillo, convertible, and stadium roof) have a black box functionality *stop material*, or more specifically *stop solid*. All three models require energy to propel closure, a shield to protect against foreign elements, and a stimulus to warrant reconfiguration. Figure 8 shows the black box model for the armadillo defense system.

The armadillo’s defense mechanism is further decomposed into a functional model, which can be compared directly to each of the similar embodied designs. The functional model, provided in Fig. 9, begins with the armadillo detecting an enemy. A control signal of fear is sent to the brain. The brain processes the control signal, which is routed to *regulate biological energy*. Biological energy is

converted to mechanical energy. Muscles transfer and change mechanical energy to position the armadillo armor into its defensive configuration, which stops the predator from penetrating.



Figure 8: Armadillo Defense Mechanism Black Box Model

Retractable roofs in athletic stadiums are functionally similar to the armadillo’s armor reconfiguration and can be modeled and compared to the armadillo as an example of biomimicry. These roofs allow stadium fields to be covered during bad weather and keep the rain, snow, wind, etc. off of the field and the spectators. The Skydome in Toronto was the first stadium to be built with a completely retractable roof. Since then, many others have been built across the globe including ones in Phoenix, Seattle, and Houston. These roofs are made up of several panels that are fastened to motorized steel wheel assemblies. Numerous motors power these wheel assemblies. When the motors are turned on, the panels move across the top of the stadium on steel rails until the stadium is closed off from the inclement weather. The Safeco Field in Seattle, Washington, has a retractable roof made up of three panels, which move an average of six inches per second for a maximum of 500 feet taking roughly 20 minutes to close the stadium’s roof depending on the wind and weather [23]. Figure 10 provides a functional model of a retractable stadium roof.

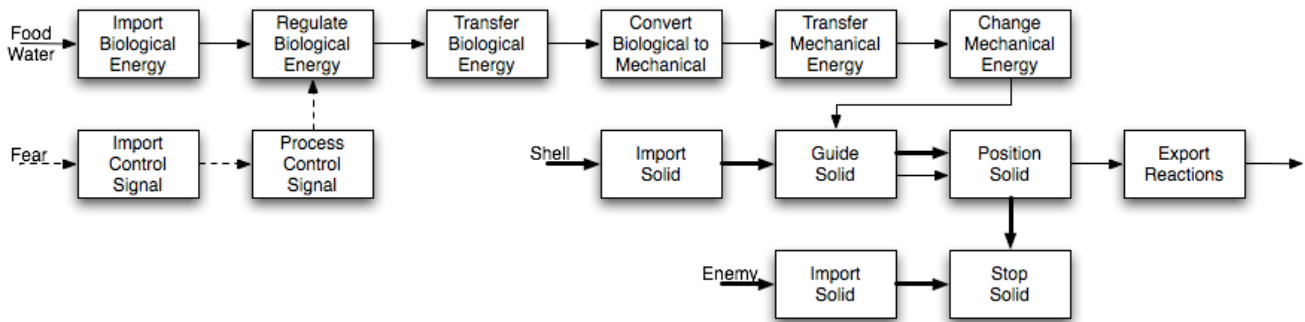

Figure 9: Functional Model of Armadillo Armor Reconfiguration

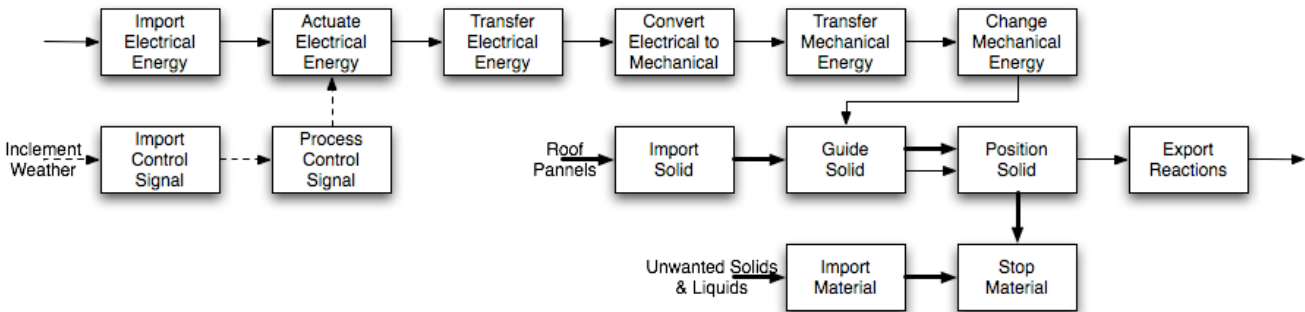

Figure 10: Functional Model of a Retractable Stadium Roof (Pannels misspelled above)

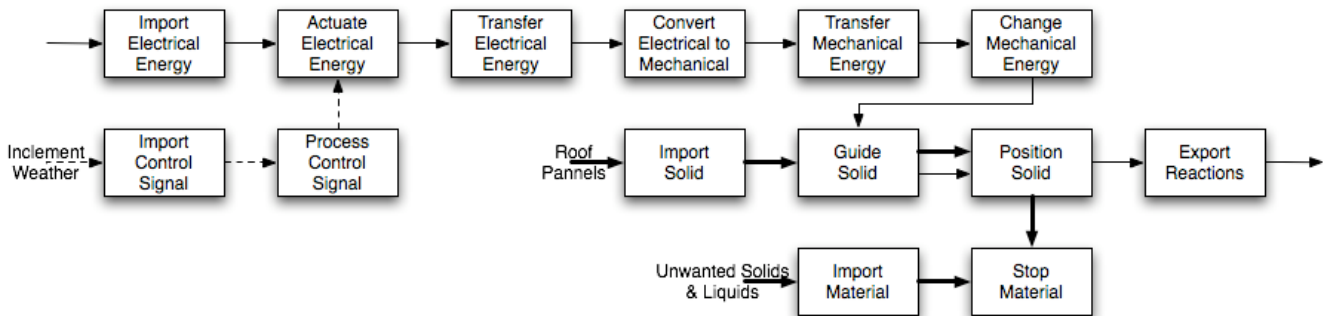

Figure 11: Functional Model of Lexus SC430 Convertible (Pannels misspelled above)

The functional model of a retractable stadium roof in Fig. 10, like that of the armadillo, uses a control signal to represent when reconfiguration is required. The processing of the signal is represented by *process control signal*, and the resulting processed signal actuates the flow of electrical energy to the system's motors. Numerous motors convert the electrical energy to mechanical energy. These motors power the wheel assemblies that the roof panels are fastened to, and the panels begin to move along the rails to close off the stadium. The motion of the panels is represented via *guide solid* and *position solid*. The unwanted inclement weather is stopped with a *stop material* function-flow block.

The Lexus SC430 has a retractable hardtop convertible roof that is able to automatically fold in half to be stored in the trunk, and like the retractable stadium roof, is functionally similar to the armadillo. The convertible's roof is made up of two panels that enable the top to fold as it is being lowered for storage. When the driver pushes a button to lower the convertible's roof, the windows roll down and the

trunk opens. The portion of the trunk closest to the driver opens, and the roof folds in half and lowers itself until it is completely inside the trunk. The trunk closes with the convertible roof folded inside [24].

The functional model generated for the opening or unfolding of the Lexus SC430's roof, shown in Fig. 11, is functionally identical to the retractable stadium roof. When inclement weather is detected, a control signal is sent to the circuit board, where the signal is processed and used to actuate the flow of electrical energy to the roof's motors. The electrical energy flows to motors, which convert the electrical energy to mechanical energy. The mechanical energy powers the closing of the roof that in turn stops the weather from reaching the inside of the car.

The armadillo, retractable stadium roof, and the Lexus SC430 convertible are functionally similar involving the *position solid* function-flow and *stop solid/material* function-flow. The models and functional solutions of the armadillo and each embodied solution are directly compared in the morphological matrix provided as Table 2.

Table 2: Combined Morphological Matrix for Armadillo, Stadium Roof, and Convertible

Function-Flow Pairs		Primary Functionality	Components	
Natural Solution	Engineered Solution		Natural Solution	Engineered Solution
Import Biological Energy	Import Electrical Energy	Import	Blood	Wires
Import Control Signal	Import Control Signal	Import	Brain	Circuit Board
Process Control Signal	Process Control Signal	Process		
Regulate Biological Energy	Actuate Electrical Energy	Control Magnitude		
Transfer Biological Energy	Transfer Electrical Energy	Transfer	Blood	Wires
Convert Biological Energy to Mechanical Energy	Convert Electrical Energy to Mechanical Energy	Convert	Muscles	Motors
Transfer Mechanical Energy	Transfer Mechanical Energy	Transfer		
Change Mechanical Energy	Change Mechanical Energy	Change		
Import Solid	Import Solid	Import	Shell	Roof Panels
Guide Solid	Guide Solid	Guide	Plates-An armadillo shell is formed by plates of dermal bone. These allow the animal to roll up.	Roof Panels-Several individual panels make up the roof of the stadium and convertible.
Position Solid	Position Solid	Position		
Import Solid	Import Material	Import	Enemy	Unwanted Solids and Liquids
Stop Solid	Stop Material	Stop	Scutes-The plates are covered by overlapping epidermal scales called scutes.	Roof
Export Reactions	Export Reactions	Export	Armadillo	Stadium/Car

Armadillos and retractable roofs have much in common from both a function and form solution perspective. From a conceptual perspective, the reconfigurable plates are directly analogous. From the morphological matrix, dissimilarity arises between the natural world and the engineered world. The difference is energy. Biological energy is the key energizer of the natural world. Biological energy is converted to mechanical energy instead of the electrical energy in the engineering world being converted to mechanical energy.

4.3 Case Study 3 – Puffer Fish

The puffer fish defense mechanism, like that of the armadillo, provides engineers with an opportunity to take cues from nature and mimic the expansion of the fish as a functional *stop* [12]. Puffer fish are known for their ability to swallow water or air to inflate their stomachs to frighten predators when threatened. This particular type of fish is not a swift swimmer. Therefore, when the fish expands its stomach to several times its normal size, a predator will find itself faced with a much larger fish and either retreat or pause long enough for the fish to get away. Water or air can be used to inflate the stomach depending on whether the animal is in or out of the water at the time of inflation. The puffer fish will continue to remain the expanded size until the threat is no longer present [25]. At this time, the air or water is expelled back out of the fish through the mouth.

At the black box level the puffer fish’s defense mechanism has the functionality of *stop solid*. The puffer fish black box model, provided in Fig. 12, requires an enemy and its associated fear as inputs as well as air, water and biological energy to expand the puffer fish. At the black box level, an automobile airbag exhibits the same

overall function, *stop solid*, as the puffer fish, thus indicating that puffer fish could inspire airbag design. An automobile airbag, however, would have different inputs than the puffer fish. An airbag would input air, chemical energies, a control signal for expansion, and the body part, in this case a human head, that it is designed to stop. The black box model for the airbag is provided in Fig. 13.

The puffer fish functional model, provided in Fig. 14, requires the control signal stimulus of fear from an enemy to activate its defense mechanism. The control signal is sent to the brain where it is processed and sent as a signal to the muscles. Biological energy is transferred to the muscles where it is converted into mechanical energy. Air or water is imported into the system filling the fish’s stomach. The inflation of the stomach fulfills the *position solid* function in the functional model. This positioning of the animal’s epidermis stops or deters the predator from attacking.

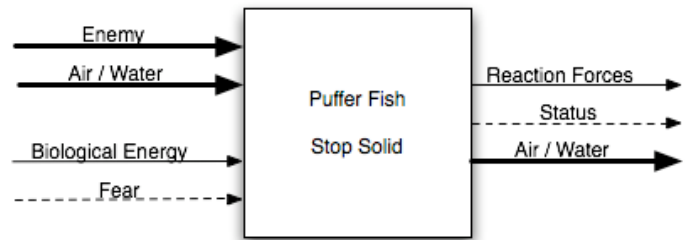

Figure 12: Puffer Fish Black Box Model

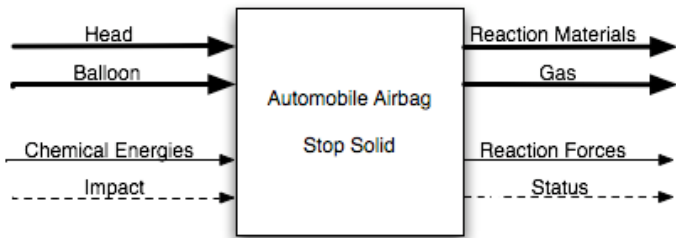

Figure 13: Automobile Airbag Black Box Model

Automobile airbags were developed for the sole purpose of slowing a passenger's speed to zero with little or no damage during an accident, and at the secondary level of the Functional Basis, would have the functionality *stop solid*. These safety devices are made up of three basic parts: the bag, a sensor, and an inflation system. The bag is made of a thin, nylon fabric that is folded into the desired location. Airbags are now used in several places including the steering wheel, dashboard, seat, and door. The sensor, which receives information from an accelerometer, tells the airbag when it needs to inflate. Unless an extreme deceleration occurs, the sensor will not activate the bag's inflation. The inflation system that was studied for this model reacts sodium azide (NaN_3) with potassium nitrate (KNO_3) to produce nitrogen gas. Hot blasts of nitrogen gas produced from this reaction are used to inflate the airbag. As soon as the airbag inflates, the deflation process begins. The nitrogen gas escapes through small vents in the fabric. Dust like particles, which are usually talcum powder or cornstarch, often escape through these vents during deflation as well [26].

The functional model that was generated for the inflation and implementation of an automobile airbag is shown in Fig. 15. Two potential chemical energies are imported and stored in the system, NaN_3 and KNO_3 . Like the puffer fish, a control signal is required to tell the system when inflation is required. In the case of the airbag, the control signal is imported after the accelerometer has indicated extreme deceleration. The control signal is processed and routed to two *supply chemical energy* function-flow blocks, which supply the chemical energies for mixing. Upon combination of the chemical energies, nitrogen gas is produced. The nitrogen gas is routed to a balloon type enclosure, which inflates and stops the human head before it hits the steering wheel or dashboard during an accident. After the airbag has been inflated, the nitrogen gas and dust particles begin to escape through vents in the airbag's balloon enclosure. This escape of reactionary elements is shown functionally with the *export reactions* and *gas* function-flow blocks.

At a high level, functional models for both the puffer fish and the automobile airbag have the same functionality, to *stop solid*. However, at the sub-function level, each performs the overall goal differently. The puffer fish, like other biological systems, requires biological energy and external air or water to perform inflation. The automobile airbag, being an engineered system, cannot practically rely on biological energy, but instead converts chemical energy to the gas required to inflate the airbag. Thus, the airbag does not import any type of material into the system because the chemical reaction inside the airbag creates the gas required to inflate the system. Table 3 provides a combined morphological matrix for the puffer fish and the automobile airbag, summarizing differences between the biological and engineered solutions for stopping a solid.

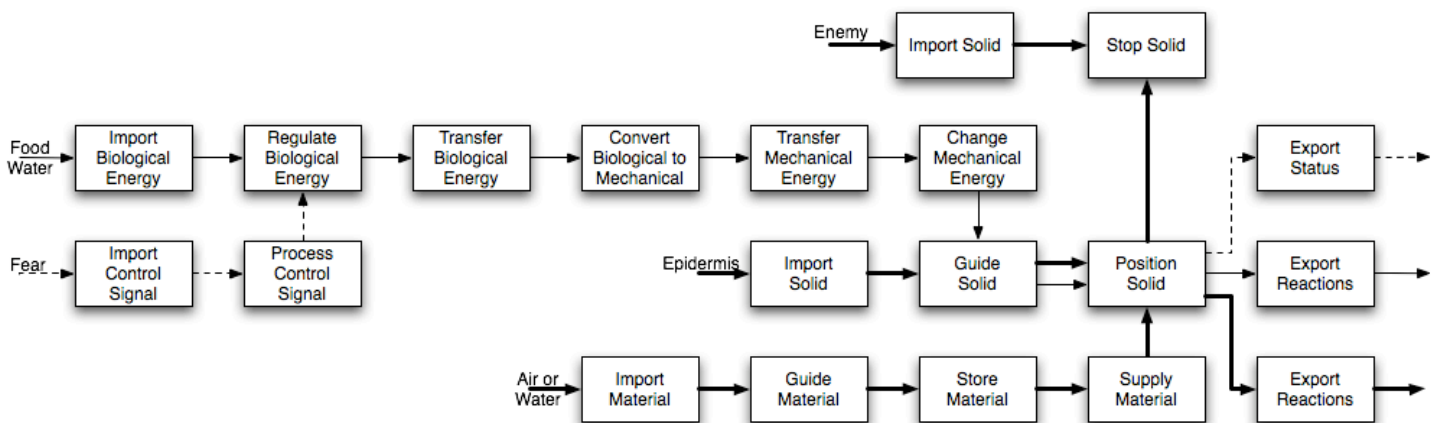

Figure 14: Functional Model of Puffer Fish

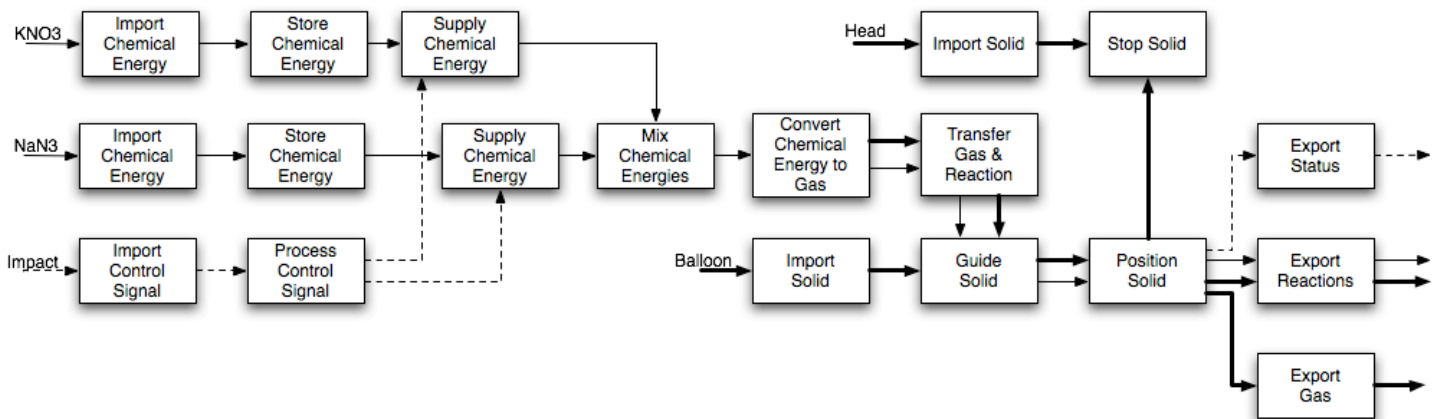

Figure 15: Functional Model of Airbag

Table 3a: Combined Morphological Matrix for Puffer Fish and Automobile Airbag

Function-Flow Pairs		Primary Functionality	Components	
Natural Solution	Engineered Solution		Natural Solution	Engineered Solution
Import Biological Energy	Import Chemical Energy	Import	Blood	KNO3
Import Biological Energy	Store Chemical Energy	Store	Import Biological Energy	KNO3
Import Biological Energy	Supply Chemical Energy	Supply	Import Biological Energy	KNO3
Import Biological Energy	Import Chemical Energy	Import	Import Biological Energy	NaN3
Import Biological Energy	Store Chemical Energy	Store	Import Biological Energy	NaN3
Import Biological Energy	Supply Chemical Energy	Supply	Import Biological Energy	NaN3
Import Control Signal	Import Control Signal	Import	Brain	Circuit Board
Process Control Signal	Process Control Signal	Process		
Regulate Biological Energy	Mix Chemical Energies	Import Control Signal		
Transfer Biological Energy	Import Control Signal	Transfer	Blood	Import Control Signal
Convert Biological Energy to Mechanical Energy	Convert Chemical Energy to Gas	Convert	Muscles	Chemical Reaction-sodium sodium azide reacts with potassium nitrate to produce nitrogen gas.
Transfer Mechanical Energy	Transfer Gas & Reaction	Transfer		Import Control Signal
Change Mechanical Energy	Import Control Signal			Import Control Signal
Import Solid	Import Solid	Import	Epidermis	Bag

Table 3b: Combined Morphological Matrix for Puffer Fish and Automobile Airbag

Function-Flow Pairs		Primary Functionality	Components	
Natural Solution	Engineered Solution		Natural Solution	Engineered Solution
Guide Solid	Guide Solid	Guide	Air/Water	Nitrogen Gas-The gas causes the bag to inflate.
Position Solid	Position Solid	Position		
Guide Material	Import Solid	Import Solid	Esophagus	Import Solid
Store Material	Import Solid	Import Solid	Stomach	Import Solid
Supply Material	Import Solid	Import Solid	Stomach	Import Solid
Import Solid	Import Solid	Import	Enemy	Human
Stop Solid	Stop Solid	Stop		
Export Status	Export Status	Export	Puffer Fish	Airbag system
Export Reactions	Export Reactions	Export	Puffer Fish	Airbag system
Export Material	Export Material	Export	Mouth	Vents
Import Material	Import Solid	Import Solid	Mouth	Import Solid

4.4 Case Study 4 – Abscission

Abscission is the process through which a plant separates leaves, fruits, and flowers from itself. Auxin, a hormone released by plants to stimulate and direct growth, is the key to abscission. When a leaf has been damaged or the plant detects that leaves are no longer supplying a sufficient amount of energy through photosynthesis (as in winter), the release of auxin is slowed. This in turn allows abscisic acid and ethylene to manifest, which advances the process of abscission by breaking down portions of the stem at the junctions where leaves are attached. The abscission zone (Fig. 16) is a layer of cells present in some plants. The cells composing the abscission zone swell and cut off the supply of nutrients in the absence of auxin [8].

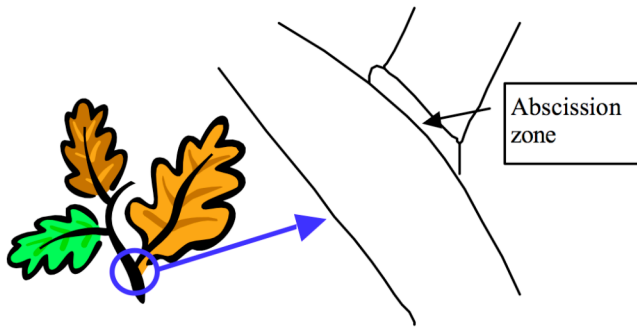

Figure 16: Abscission Zone [8]

The strategy that can be derived from the process of abscission is the utilization of an intermediate (abscission) zone to facilitate the separation of parts. The process of abscission was modeled in the Functional Basis and is shown in Fig. 17.

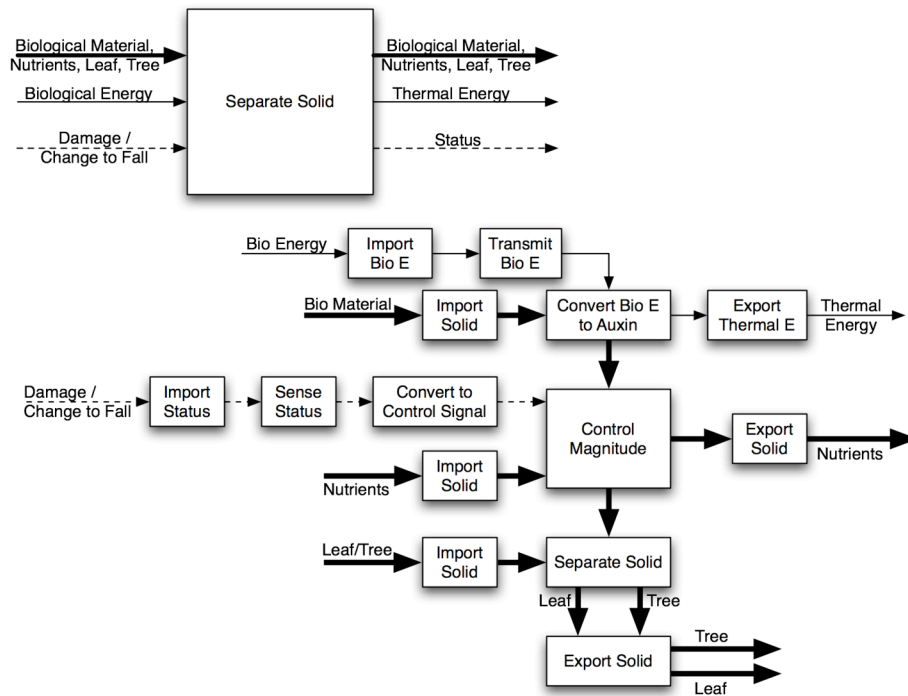

Figure 17: Functional Model of Abscission

The process of separation of a damaged or unwanted leaf from a plant is initiated by a status signal representing the detection of damage or the changing from summer to fall. This status signal is converted to a control signal as the plant regulates the release of auxin. Auxin is the result of a conversion of biological energy and material, and a decrease in its levels triggers the separation of the leaves from the tree.

While water and nutrients are absorbed from the soil through the roots, a large portion of a plant's mass is made up of carbon absorbed from the atmosphere via leaves. This matter and energy is transported throughout the plant through the xylem and phloem, the two types of transport tissue in plants. Thermal energy is discharged from the plant as a result of photosynthesis and other energy conversions that take place. Auxin is synthesized in plant cells and allows for reaction to environmental changes without the need for a central nervous system. The cells adjust the rate of auxin synthesis based on energy efficiency. When photosynthetic efficiency decreases, a hormonal imbalance is created, triggering the process of abscission. Abscisic acid and ethylene manifest due to a lack of auxin. These chemicals are responsible for the breakdown of plant matter in the abscission zone. Gravity and wind carry the unwanted leaves away [27].

An analogous engineered system that was analyzed for comparison was a proposed method of microassembly abscission [8] where an intermediate zone is broken down to enable separation. A tool, such as a robot arm end-effector can be positioned and a post-process can then chemically or thermally remove the sacrificial part of the tool. A proposed tool is shown in Fig. 18. The sacrificial part of the tool is released with the object, and the significant size and weight of the sacrificial part allows the object to be easily oriented and released. The gripper, sacrificial part, and microobject are analogous to the plant, abscission zone, and leaf respectively.

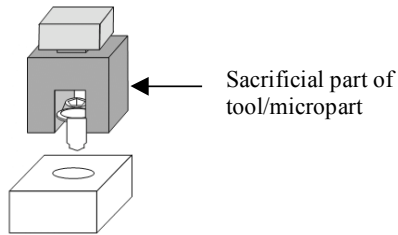
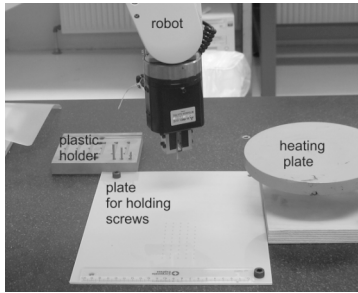
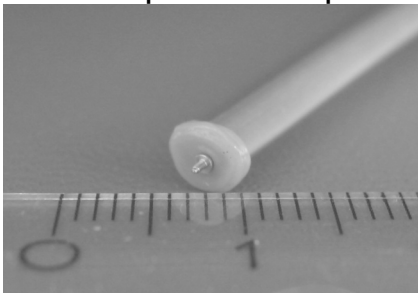

Figure 18: Microgripper with Sacrificial Part [8]

Figure 19 shows an interesting interpretation of this process that was implemented and tested at the Technical University of Denmark. The specific microassembly process was that of mating a 0.6 mm microscrew with a plastic counterpart.



a. Experimental Setup



b. Microscrew Embedded into Polypropylene Rod

Figure 19: Abscission-Based Release Implementation [8]

A polypropylene rod is melted at the tip and placed onto the microscrew. Upon contact, the plastic solidifies and creates a firm connection. The microscrew is inserted into the plastic counterpart, and the terminal torque increase breaks it from the polypropylene rod. Figure 20 shows the functional model of this process.

A processor sends control signals to the robotic arm that controls the picking, positioning and turning of the screw and rod. A heating plate transmits thermal energy through direct contact with the rod, whose melted tip contacts the screw. Solidification of the tip causes the mating of the rod and screw, and a torque increase breaks the bond between the screw and polypropylene rod. Reaction forces and thermal energy are released as byproducts. Finally, the robotic arm removes the polypropylene rod.

Based on a function-function comparison, the microassembly process is different from the biological phenomenon that inspired it. The analogy exists from a process or strategic perspective. In this case of microassembly abscission, the screw is imported and secured to the polypropylene rod through the local heating and cooling of the end of the rod. Mechanical energy in the form of rotation is used to position and tighten the screw, ultimately resulting in the release of the screw due to an increase in torque. In both the natural and engineered systems, the objective is to separate two objects through the functionality of an intermediary. Plants use chemical processes to reach this result, whereas the model in Fig. 20 uses torque to overcome the bond between the screw and polypropylene rod.

A combined morphological matrix of the natural and engineered models is shown in Table 4. Because the biomimicry is based on strategy, there is difference in the function-flow pairs between the two systems. Many plant solutions occur at the cellular level, a capability the engineered system lacks.

The functional models for the biological and engineered processes suggest the possibility of alternative approaches to similar problems. The process, method, functionality and form solution of abscission can lead to other innovative concepts. For example, developing a bonding agent and gas that work in the same manner as abscission could serve as a useful design for disposal or reuse. Products joined with this bonding agent could be exposed to the gas at the end of life to facilitate disassembly for disposal or repair.

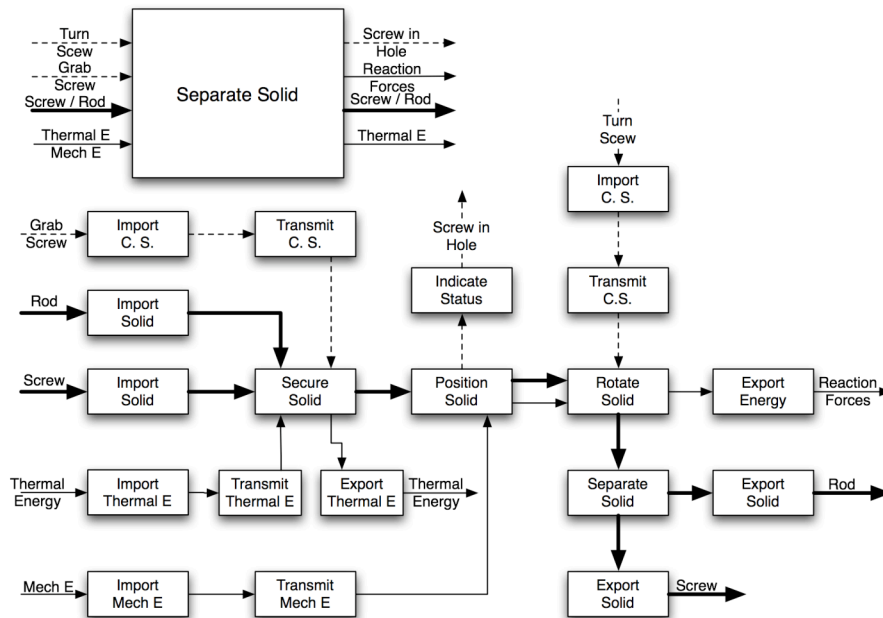

Figure 20: Functional Model of Microassembly Abscission

Table 4: Combined Morphological Matrix for Abscission and Abscission-Based Microassembly

Function-Flow Pairs		Primary Functionality	Components	
Natural Solution	Engineered Solution		Natural Solution	Engineered Solution
Import Biological Energy	Import Mechanical Energy	Import	Roots and Leaves	Motor
Import Biological Energy	Import Thermal Energy		Roots and Leaves	Heating Plate
Transmit Biological Energy	Transmit Thermal Energy	Transmit	Xylem and Phloem	Heating Plate
Transmit Biological Energy	Transmit Mechanical Energy		Xylem and Phloem	Robotic Actuators
Import Solid	Import Solid	Import	Roots	Robotic Actuators
Convert Biological Energy to Auxin	Convert Biological Energy to Auxin	Convert	Plant Cells	Convert Biological Energy to Auxin
Export Thermal Energy	Export Thermal Energy	Export	Plant Cells	Polypropylene Rod Cooling
Export Thermal Energy	Export Energy		Plant Cells	Reaction Forces
Import Status	Import Control Signal	Import	Plant Cells	Processor
Sense Status	Indicate Status	Signal	Plant Cells	Sensors
Convert Status to Control Signal	Convert Status to Control Signal	Convert	Plant Cells	Convert Status to Control Signal
Control Magnitude	Control Magnitude	Control Magnitude	Plant Cells	Control Magnitude
Control Magnitude	Transmit Control Signal	Transmit	Control Magnitude	Data Cables
Control Magnitude	Secure Solid	Secure	Control Magnitude	Polypropylene Rod Cooling
Control Magnitude	Position Solid	Position	Control Magnitude	Robotic Actuators
Control Magnitude	Rotate Solid	Rotate	Control Magnitude	Robotic Actuators
Separate Solid	Separate Solid	Separate	Abscisic Acid and Ethylene	Robotic Actuators
Export Solid	Export Solid	Export	Gravity and Wind	Robotic Actuators

5 DISCUSSION OF RESULTS

The research reported in this article has two important results. First, through the use of the Functional Basis, natural systems can be functionally modeled as if they were engineered systems. Second, given a functional model, engineered systems with similar functionality to the natural system can adapt solution principles from the natural system. Functional representation creates a immediate vehicle for biomimetic design.

Another discovery of this research is the observation that a crucial difference between natural and engineered systems is the energy source. In nature, energy was modeled as biological. In the engineered systems, it was modeled according to its engineering specification. The different energy flows resulted in differing function-flow pairs between natural and engineered systems. Note that the actual function (*convert* for example) is the same. Thus to find analogy, the search is by function alone, not function and flow. Future work will explore the modeling of effort-flow pairs to see if this yields more innovative results.

Further work will include the investigation of modeling nature from multiple perspectives. One of the discoveries of this research is that modeling different aspects of a natural system leads to different functional models and different analogies. In the case studies, the biomimetic designs and analogous natural systems were identified before creating the functional models. The goal was to discover if functional modeling would serve as an appropriate representation for

biomimetic design. Thus, as future work, different aspects of natural systems will need to be modeled prior to identifying an analogous engineered system. The goal is to explore the potential impact on innovation in engineering design. The modeling possibilities are limitless and can include entire cellular interactions, complete organisms, population interactions, as well as ecosystems. Process modeling techniques should also be employed to model state change in the natural world, for instance, aging and seasons.

6 CONCLUSIONS

Biomimetic design can provide new inspiration and increased efficiency in engineering by bringing about clever and novel design solutions. This research proves the feasibility of using functional modeling and the Functional Basis as a means to capture the natural world. Case study examples including functional models and morphological matrices demonstrate that relationships can be made at the functional level between embodied engineered solutions and those found in nature. The comparison of both the natural and engineered solutions shows that the elegance, simplicity, and efficiency of natural solutions can lead to innovative engineered systems through direct imitation, as in the case of flapping winged flight, or broader strategic methods, as in the case of abscission and micro-manufacturing.

Modeling natural systems functionally gives engineers a clear understanding of the natural world. Engineers are not required to

translate natural solutions from the biological domain to the engineering domain, and novel, natural solutions, that would otherwise go unrecognized, can be provided in engineering terms ready for design application. However, for functional models of the natural world to be useful to design engineers, they must be translated with a functional basis and made accessible to design engineers. Future work will include further translation of natural designs, and the creation of a biomimetic library for use with the UMR design repository for storing the translated functional information of nature's designs, thus allowing the information to be accessible from around the world.

7 REFERENCES

1. Otto, K.N. and K.L. Wood, *Product design: techniques in reverse engineering and new product development*. 2001, Upper Saddle River, NJ: Prentice Hall, xxi, 1071.
2. Bohm, M. and R. Stone. *Product Design Support: Exploring a Design Repository System*, in *ASME International Mechanical Engineering Congress*. 2004. Anaheim, CA.
3. Bohm, M. *Design Engineering Lab: Design Repository Login*, 2004, [cited March 2004]; Available from: <http://module.basiceng.umn.edu:8080/view/>.
4. Bohm, M., R. Stone, and S. Szykman, *Enhancing Virtual Product Representations for Advanced Design Repository Systems*, *Journal of Computer and Information Science in Engineering*, 2005, **5**(4): p. 360-372.
5. Bohm, M. and R. Stone. *Representing Product Functionality to Support Reuse: Conceptual and Supporting Functions*, in *Proceedings of DETC2004*. 2004. Salt Lake City, UT.
6. Paturi, F., *Nature, Mother of Invention: The Engineering of Plant Life*. 1976, London: Thames and Hudson.
7. Hacco, E., Shu, L.H., *Biomimetic Concept Generation Applied to Design for Remanufacture*, in *DETC*. 2002, ASME: Montreal, Canada.
8. Shu, L.H., Hansen, H.N., Gegeckaitis, A., Moon, J., Chan, C., *Case Study in Biomimetic Design: Handling and Assembly of Microparts*, in *IDETC/CIE*, 2006, ASME: Philadelphia, PA.
9. Chakrabarti, A., Sarkar, P., Leelavathamma, B., Nataraju, B.S., *A Functional Representation for Aiding Biomimetic and Artificial Inspiration of New Ideas*, *Artificial Intelligence for Engineering Design, Analysis and Manufacturing*, 2005, **19**(2): p. 113-132.
10. Hirtz, J., et al., *A Functional Basis for Engineering Design: Reconciling and Evolving Previous Efforts*, *Research in Engineering Design*, 2002, **13**(2): p. 65-82.
11. Linsey, J.S., Murphy, J.T., Markman, A.B., Wood, K.L., Kurtogula, T., *Representing Analogies: Increasing the Probability of Innovation*, in *IDETC/CIE*. 2006, ASME: Philadelphia, PA.
12. Singh, V., Skiles, S.M., Krager, J.E., Wood, K.L., Jensen, D., Szmerekovsky, A., *Innovations in Design through Transformation: A Fundamental Study of Transformation Principles*, in *IDETC/CIE 2006*, ASME: Philadelphia, PA.
13. Biomimicry Institute. *Biomimicry - Nature as Model, Measure and Mentor*, 2006 [cited 2007 Feb. 10]; Available from: <http://www.biomimicry.net/>.
14. Biomimicry Institute. *Biomimicry Institute*, 2006 [cited 2007 Feb. 10]; Available from: <http://www.biomimicryinstitute.org/>.
15. Chu, A., Kazerooni, H., Zoss, A. *On the Biomimetic Design of the Berkeley Lower Extremity Exoskeleton (BLEEX)*, in *Proceedings of the IEEE*. 2005. Barcelona, Spain.
16. Behkam, B., Sitti, M., *Design Methodology for Biomimetic Propulsion of Miniature Swimming Robots*, *Transactions of the ASME*, 2006, **128**(1): p. 36-43.
17. Ornithopter Zone, Nathan Chronister., *Ornithopter Media Collection*, [cited 2007 Feb. 22]; Available from: <http://www.ornithopter.org>.
18. Żbikowski, R., *Fly Like a Fly*, in *IEEE Spectrum*. November 2005.
19. *Housefly*. [cited 2007 Feb. 25]; Available from: http://en.wikipedia.org/wiki/House_fly.
20. Dickinson, M., F. Lehmann, S. Sane, *Wing Rotation and the Aerodynamic Basis of Insect Flight*, *Science*, 1999, **284**(5422): p. 1954-1960.
21. Agrawal, S.K. *Sparrow Flapping Wing Micro Air Vehicle*. [cited 2007 Feb. 10]; Available from: <http://mechsys4.me.udel.edu/research/birdproject/>.
22. Nixon, J. *Armadillo Online!* 2006 [cited 2006 Nov. 8]; Available from: <http://www.msu.edu/~nixonjos/armadillo/>.
23. *Safeco Field*. June 17, 1999 [cited 2006 Nov 27]; Available from: <http://www.djc.com/special/safeco/10053886.htm>.
24. *How Convertibles Work*. 2006 [cited 2006 Nov. 27]; Available from: <http://auto.howstuffworks.com/convertible.htm>.
25. *UCI Biomechanics*. September 23, 2005 [cited 2006 Nov. 8]; Available from: <http://www.biomechanics.bio.uci.edu/>.
26. *How Airbags Work*. 2006 [cited 2006 Nov. 27]; Available from: <http://auto.howstuffworks.com/airbag.htm>.
27. *Abcission*. [cited 2007 Feb. 25]; Available from: <http://en.wikipedia.org/wiki/Abcission>.